

REVISION RECORD				
REV	ECN	DESCRIPTION	DRFT	DATE

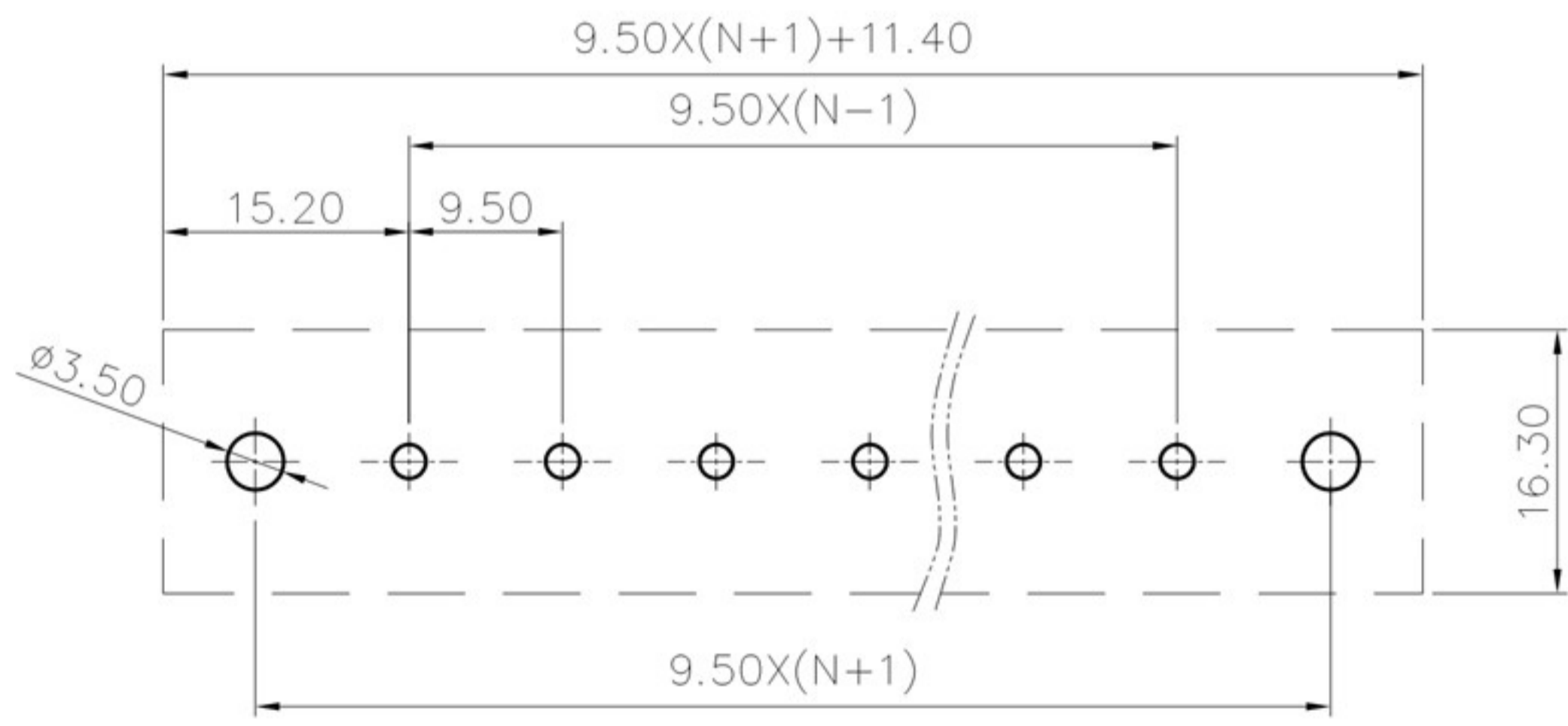
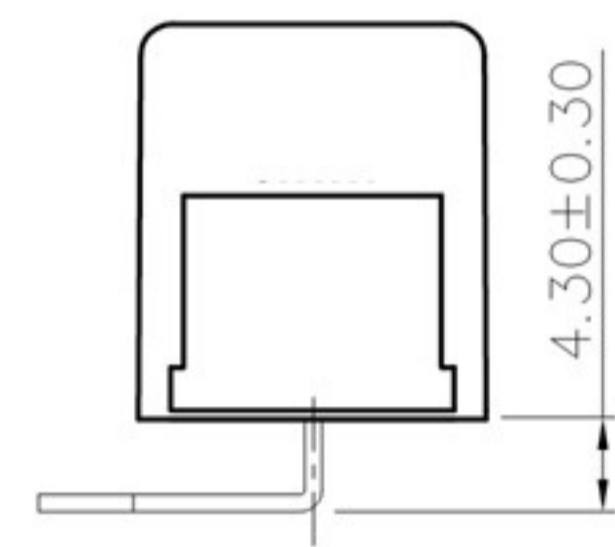
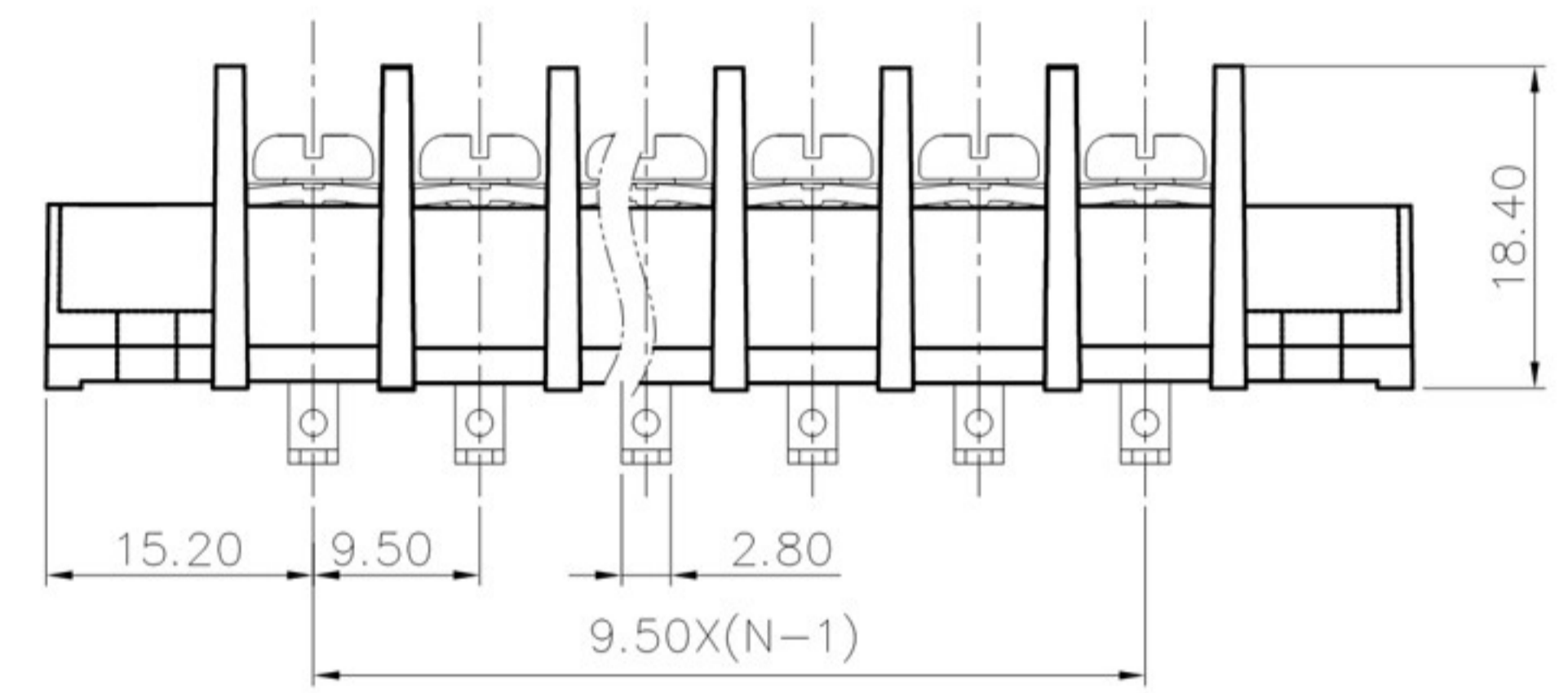
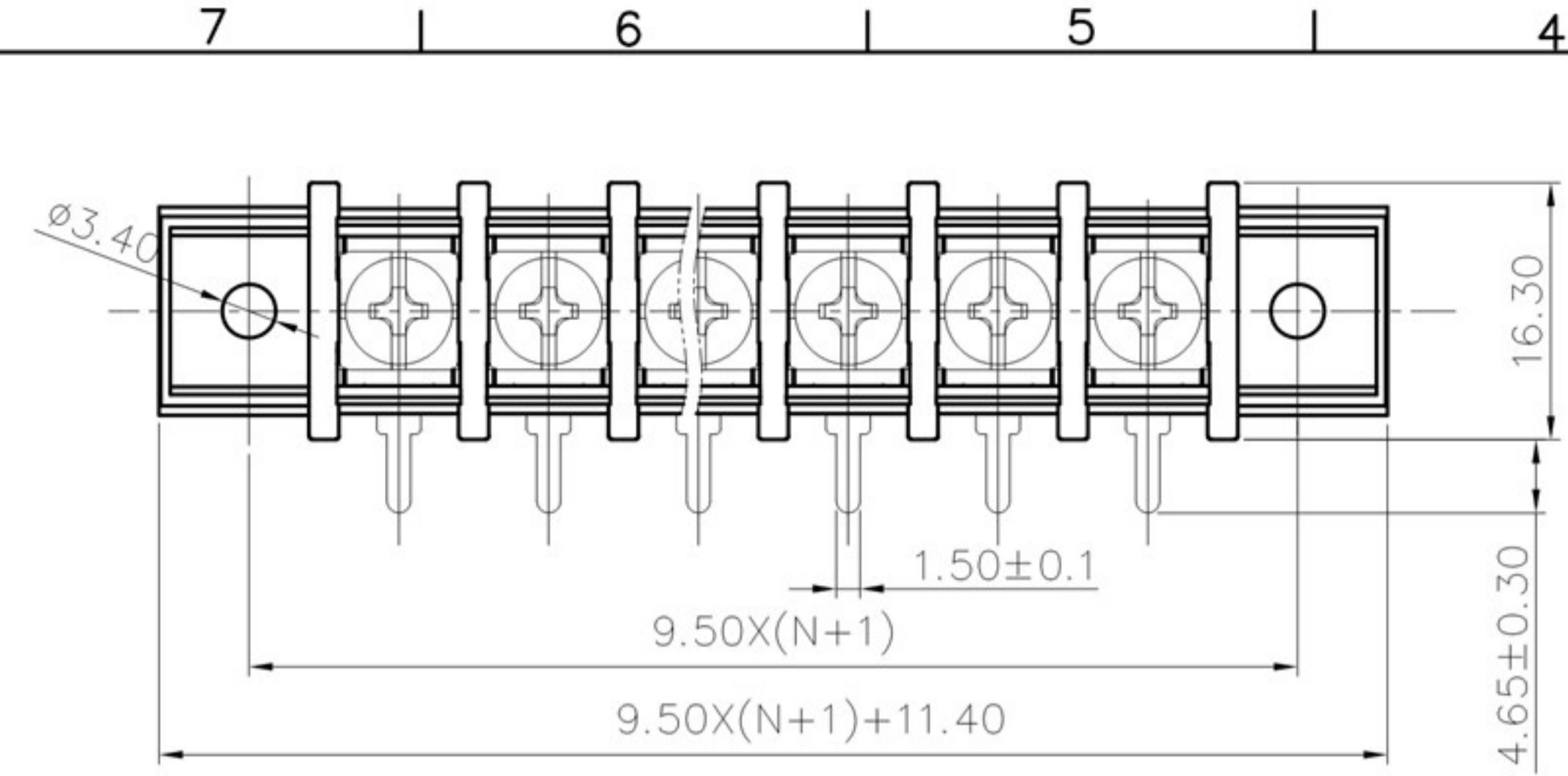

PCB LAYOUT

NOTES1:

- UL Standard
- 1.Rated voltage/current : 300V / 25A
- 2.Torque value : M4 , 10.53Lb.in
- 3.Wire range : 22~12AWG

NOTES2:

- 1.Dimension shall be interpreted per ASME Y14.5-2009
- 2.Pitch : 9.50mm, Poles : N=02~24P
- 3.Withstanding voltage : AC1600V/1Min
- 4.Operating temperature: -40°C~+105°C
- 5.Undimensioned tolerances:

Pitch range in mm		Nominal dimension range in mm						-	∩	∇
TO	Over	TO	Over	TO	Over	TO	Over	TO	Over	0.1/10
6	6	10	10	24	30	30	60	100	150	<
±0.15	±0.20	±0.30	±0.30	±0.50	±0.70	±1.00	±1.30	±2'		

6.RoHS Compliance

DETACHED LISTS	PART NO.:	慈溪市美感电子接插件厂 Cixi Meigan Electric Appliance Socket Factory			
	APPD:	NAME: MG45RM-9.5			
	CHKD:	TITLE: CUSTOMER DRAWING		REV	D0
	DRFT:	DRAWING NO.:		SHEET	1/1
	THIRD ANGLE PROJECTION		MM (INCH)	DO NOT SCALE DRAWING	SCALE