

REVISION RECORD				
REV	ECN	DESCRIPTION	DRFT	DATE

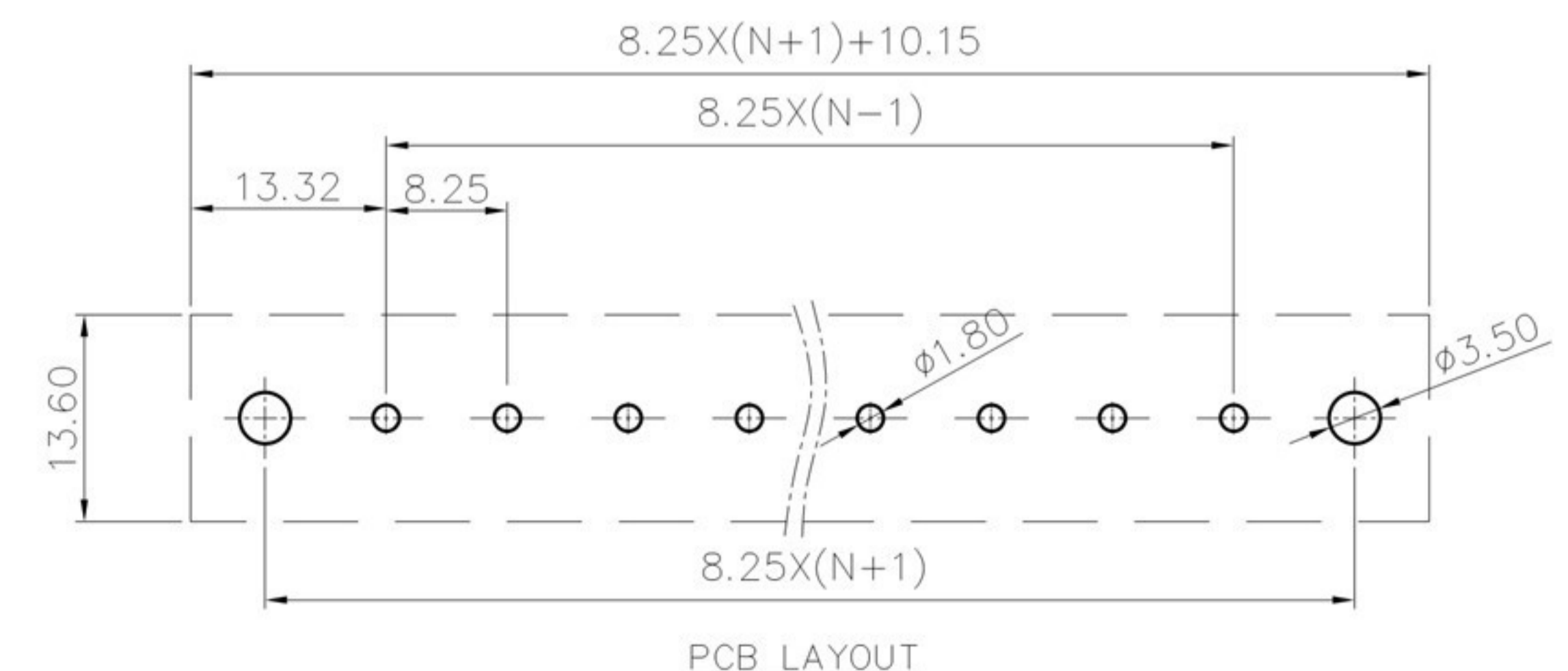
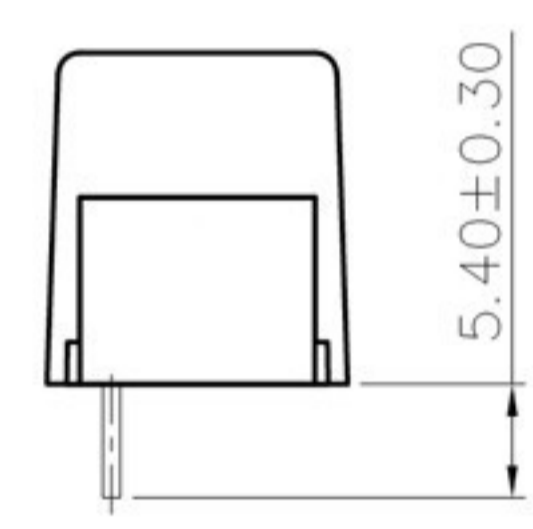
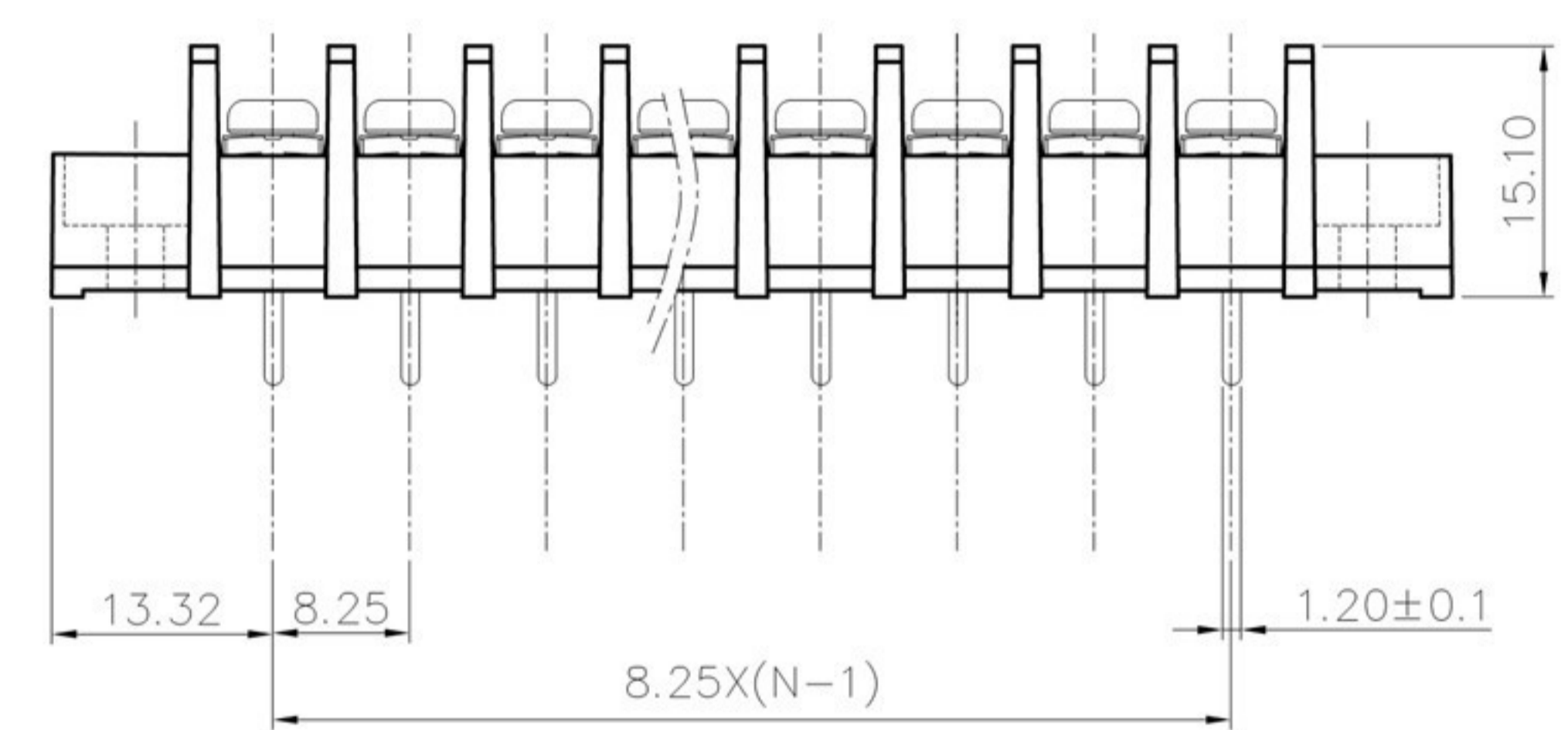
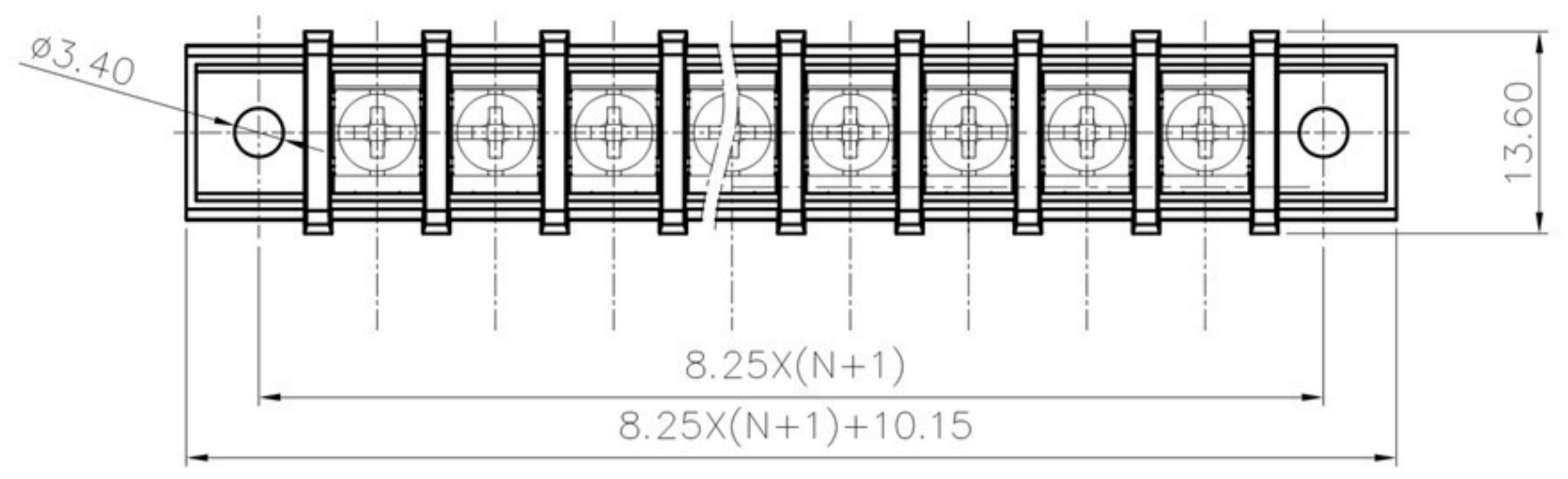

NOTES1:  
 UL Standard  
 1. Rated voltage/current : 300V / 20A  
 2. Torque value : M3 , 4.43Lb.in  
 3. Wire range : 22~12AWG

NOTES2:  
 1. Dimension shall be interpreted per ASME Y14.5-2009  
 2. Pitch : 8.25mm, Poles : N=02~24P  
 3. Withstanding voltage : AC1600V/1Min  
 4. Operating temperature: -40°C~+105°C  
 5. Undimensioned tolerances:

Pitch range in mm		Nominal dimension range in mm						-	$\cap$	$\square$
TO	Over	TO	Over	TO	Over	TO	Over	TO	Over	
6	10	24	30	60	100	150	150	150	150	
$\pm 0.15$	$\pm 0.20$	$\pm 0.30$	$\pm 0.30$	$\pm 0.50$	$\pm 0.70$	$\pm 1.00$	$\pm 1.30$	$\pm 2'$	$\pm 2'$	

6. RoHS Compliance

DETACHED LISTS	PART NO.:	慈溪市美感电子接插件厂 Cixi Meigan Electric Appliance Socket Factory			
	APPD:	NAME: MG35SM-8.25			
	CHKD:	TITLE: CUSTOMER DRAWING			
	DRFT:	DRAWING NO.:		REV	DO
	THIRD ANGLE PROJECTION		MM (INCH)	DO NOT SCALE DRAWING	SHEET 1/1
		SCALE	1:1		