

7 6 5 4 3 2 1

REVISION RECORD				
REV	ECN	DESCRIPTION	DRFT	DATE

(W/O COVER)

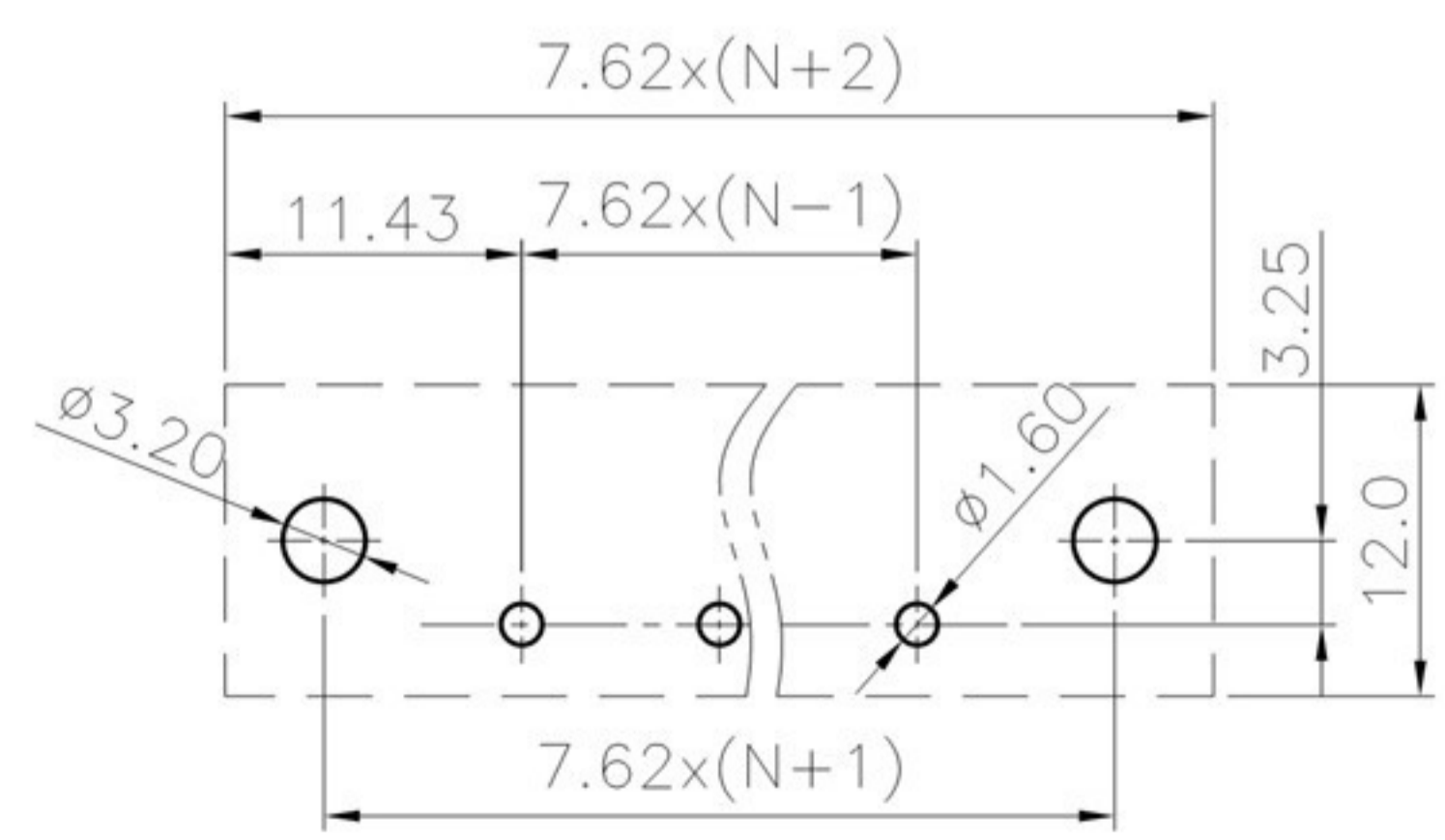
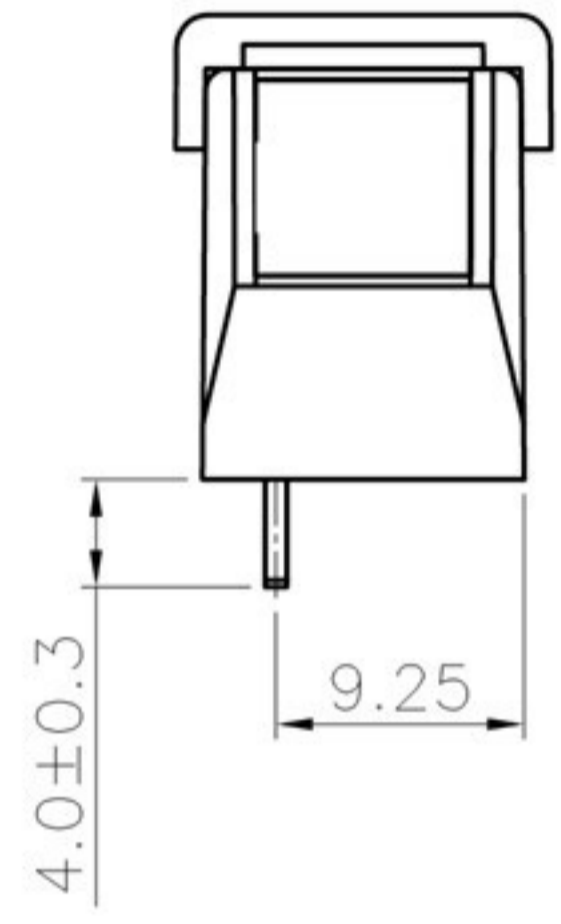
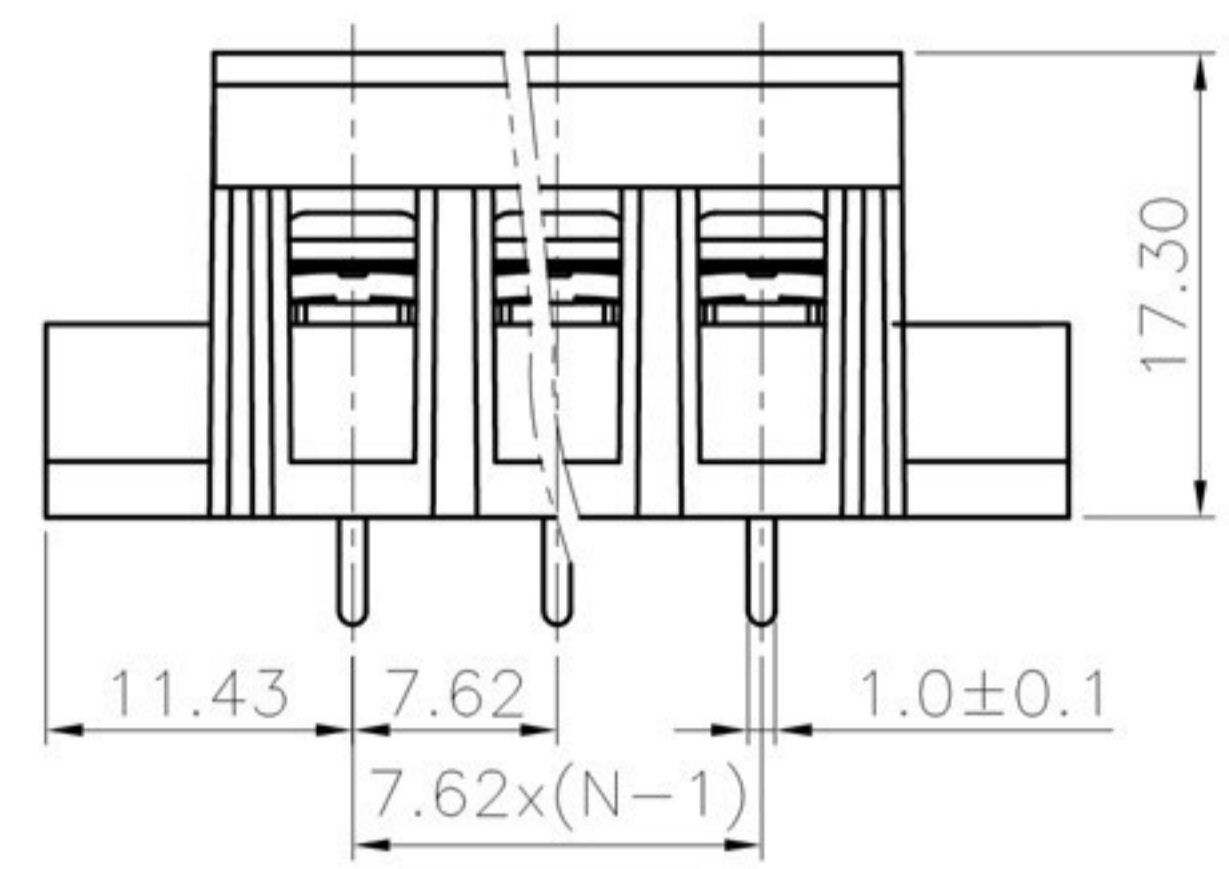
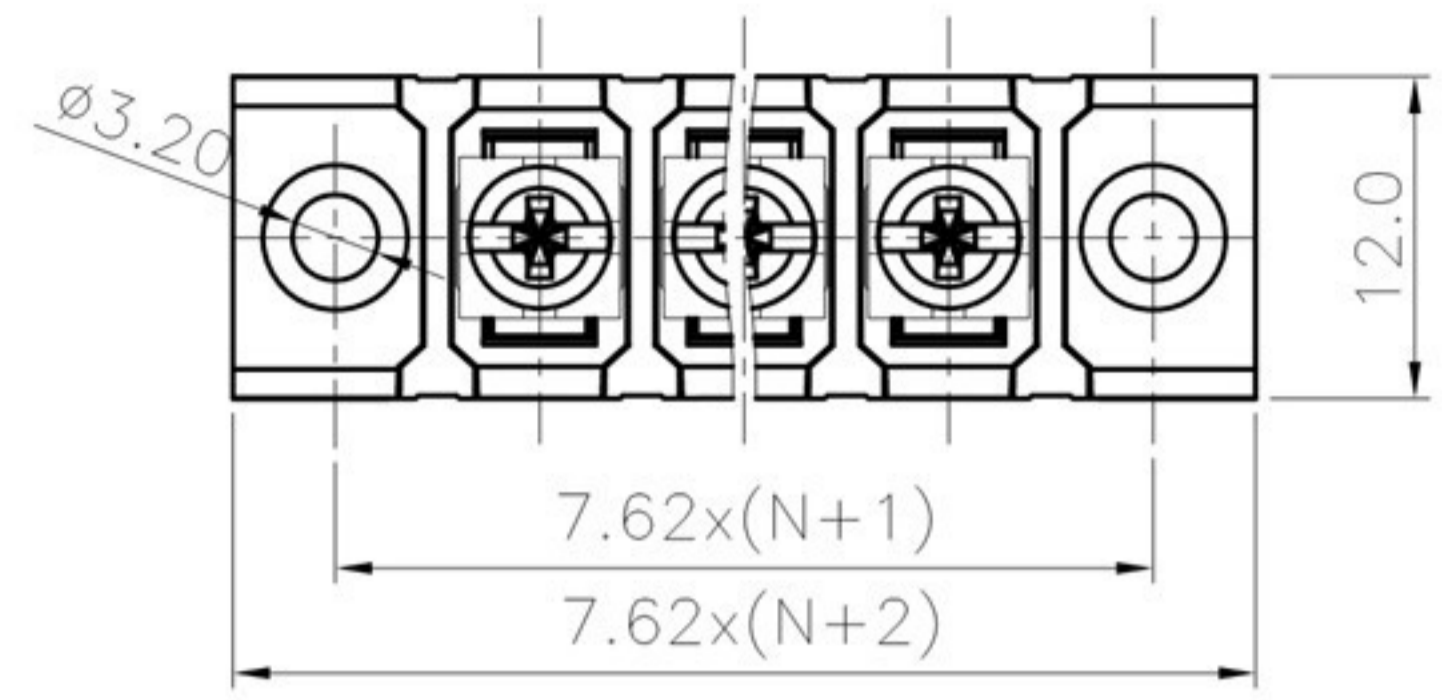

PCB LAYOUT

NOTES1:

- UL Standard
- 1. Rated voltage/current : 300V / 15A
- 2. Torque value : M3 , 4.43Lb.in
- 3. Wire range : 22~14AWG

NOTES2:

- 1. Dimension shall be interpreted per ASME Y14.5-2009
- 2. Pitch : 7.62mm, Poles : N=02~24P
- 3. Withstanding voltage : AC1600V/1Min
- 4. Operating temperature: -40°C~+105°C
- 5. Undimensioned tolerances:

Pitch range in mm		Nominal dimension range in mm					-	∩	∇
TO	Over TO	Over TO	TO	Over TO	Over TO	Over TO	0.1/10		
6	10	24	30	60	100	150		<	
±0.15	±0.20	±0.30	±0.30	±0.50	±0.70	±1.00	±1.30	±2'	

6. RoHS Compliance

DETACHED LISTS	PART NO.:	慈溪市美感电子接插件厂 Cixi Meigan Electric Appliance Socket Factory			
	APPD:	NAME: MG28SM-7.62			
	CHKD:	TITLE: CUSTOMER DRAWING			
	DRFT:	REV	DO		
	DRAWING NO.:		SHEET	1/1	
THIRD ANGLE PROJECTION		MM (INCH)	DO NOT SCALE DRAWING	SCALE	1:1

H
G
F
E
D
C
B
A

H
G
F
E
D
C
B
A

8 7 6 5 4 3 2 1