

REVISION RECORD				
REV	ECN	DESCRIPTION	DRFT	DATE

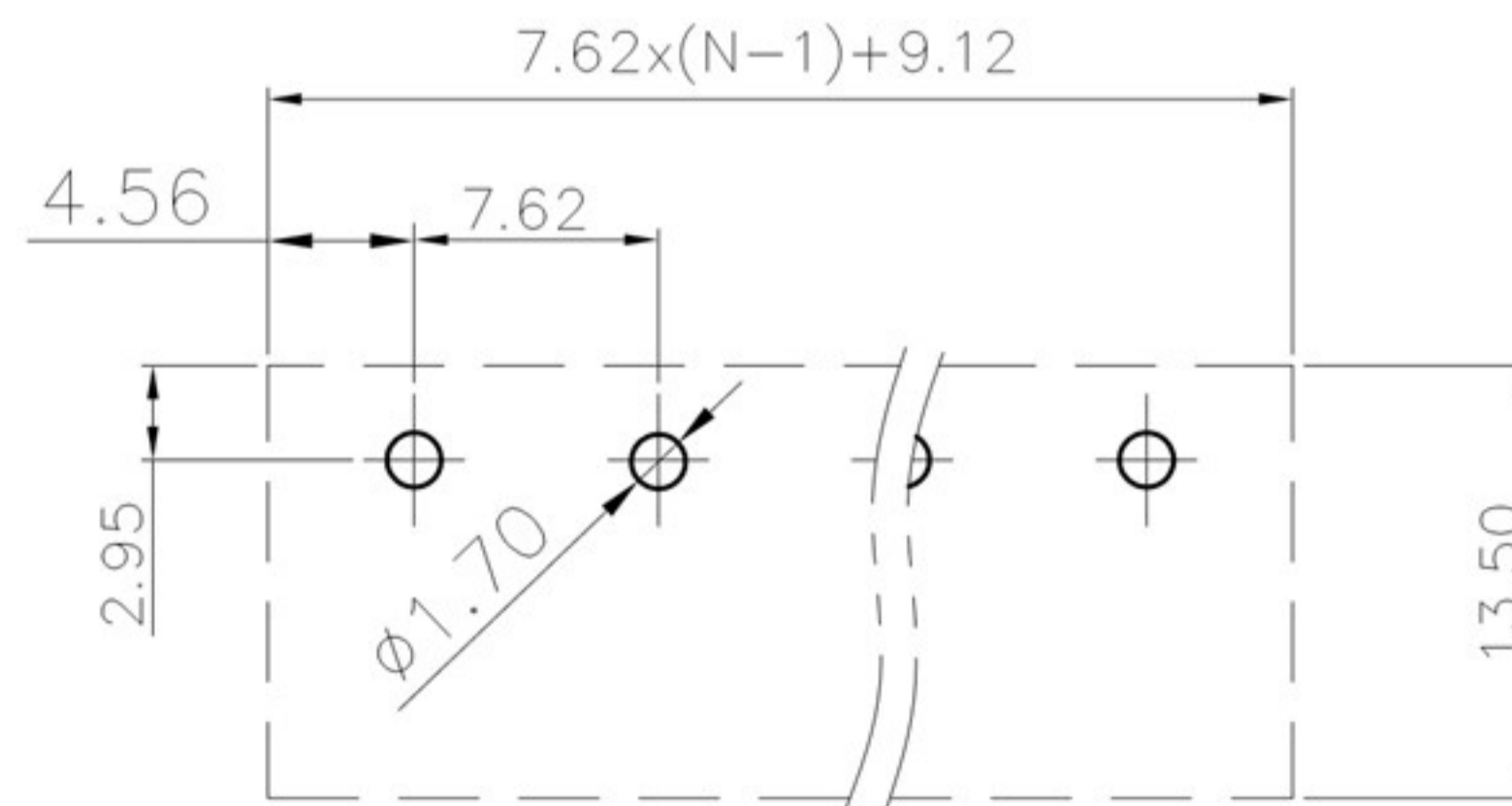

PCB LAYOUT

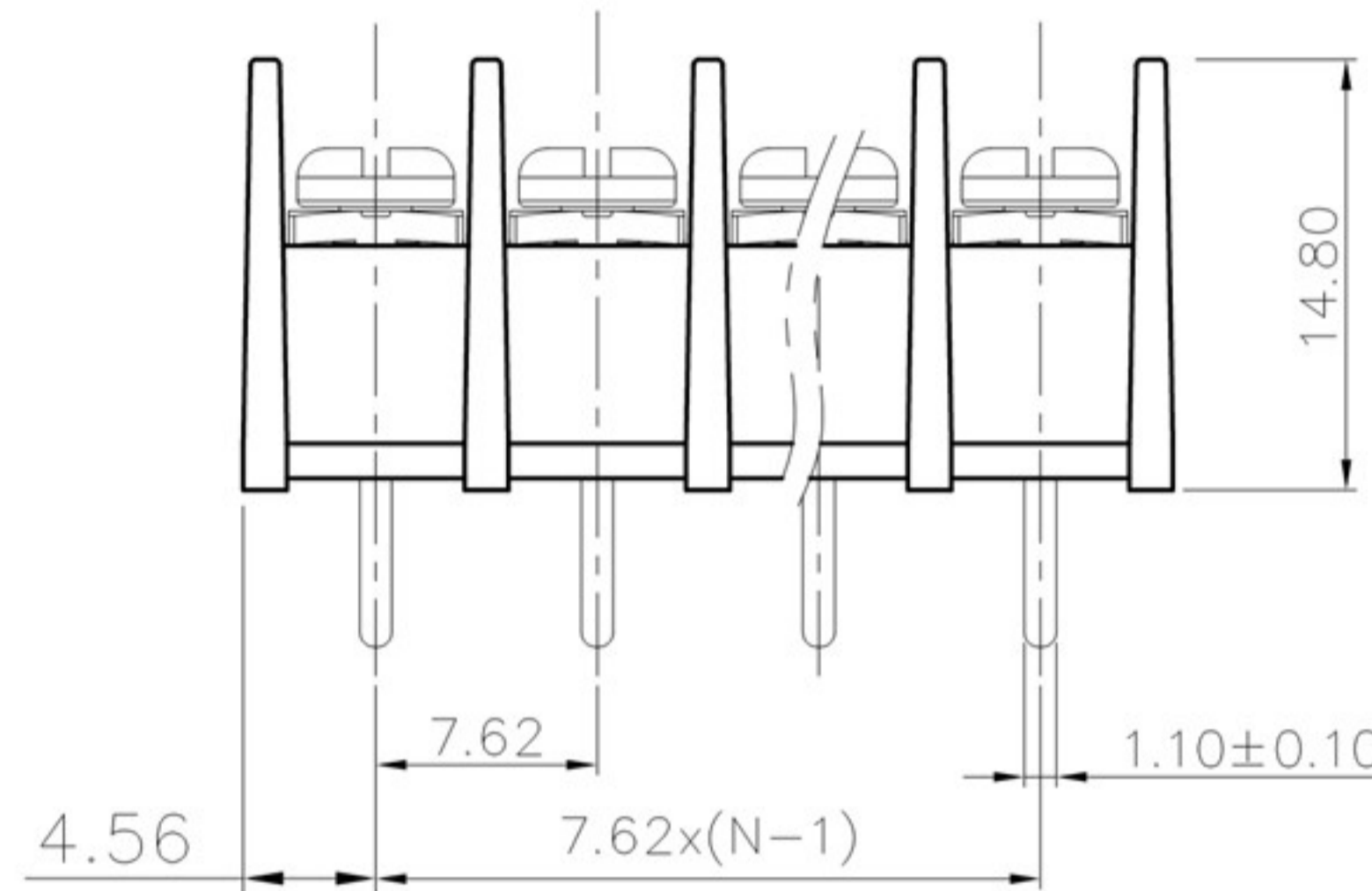
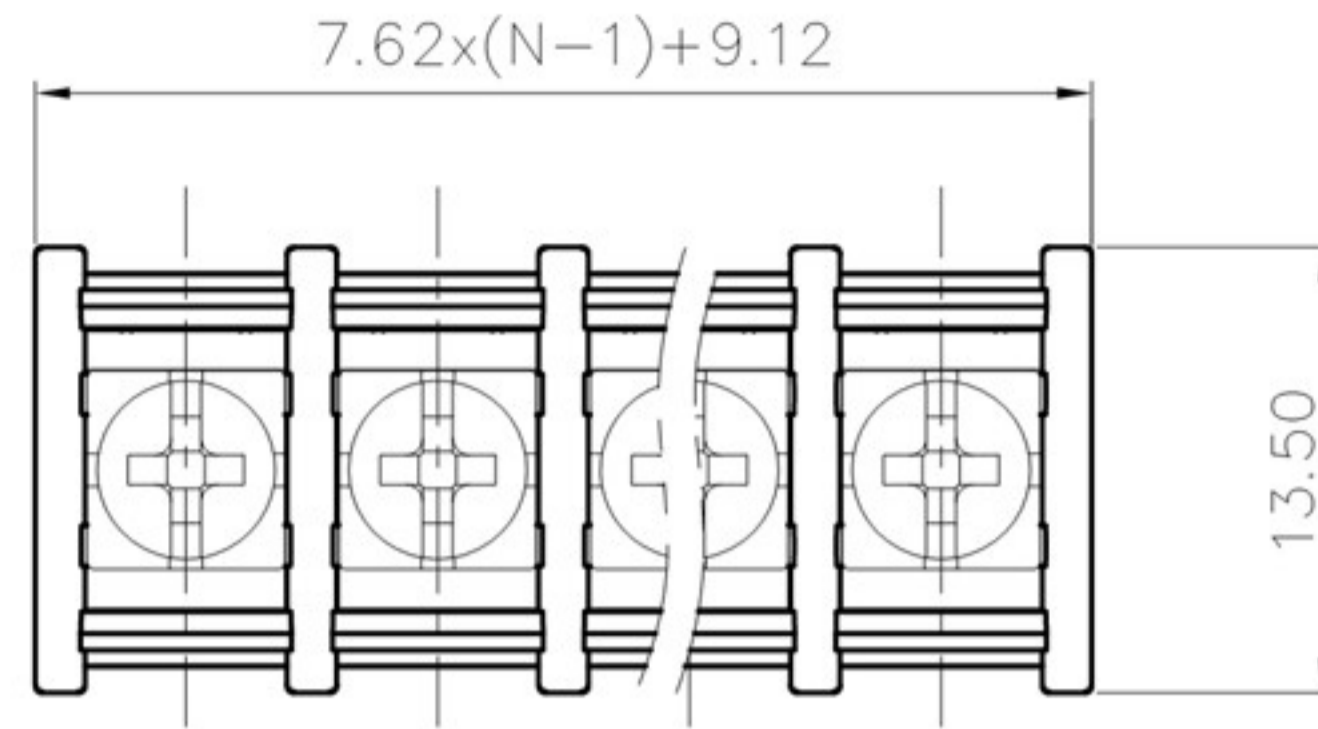
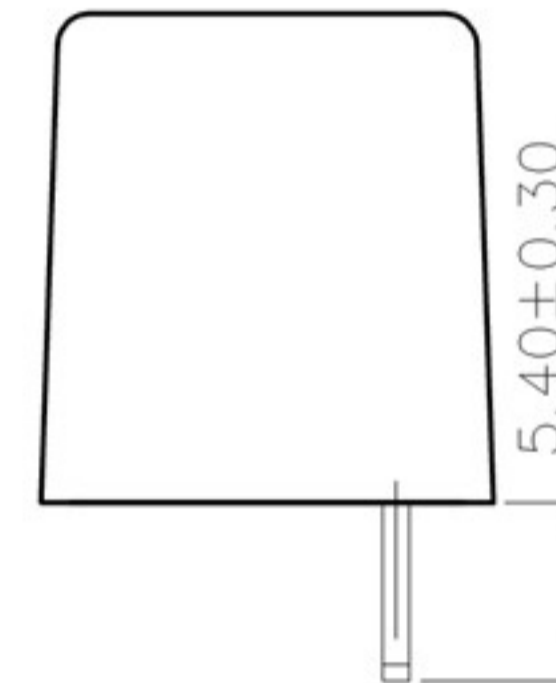

NOTES1:

- UL Standard
- 1.Rated voltage/current : 300V / 15A
- 2.Torque value : M3 , 4.43Lb.in
- 3.Wire range : 22~14AWG

NOTES2:

- 1.Dimension shall be interpreted per ASME Y14.5-2009
- 2.Pitch : 7.62mm, Poles : N=02~24P
- 3.Withstanding voltage : AC1600V/1Min
- 4.Operating temperature:-40°C~+105°C
- 5.Undimensioned tolerances:

Pitch range in mm		Nominal dimension range in mm						-	∩	∇
TO	Over TO	Over TO	TO	Over TO	Over TO	Over TO	Over TO	0.1/10		
6	10	24	30	60	100	150		<		
±0.15	±0.20	±0.30	±0.30	±0.50	±0.70	±1.00	±1.30	±2'		

- 6.RoHS Compliance

DETACHED LISTS	PART NO.:	慈溪市美感电子接插件厂 Cixi Meigan Electric Appliance Socket Factory			
	APPD:	NAME: MG25S-7.62			
	CHKD:	TITLE: CUSTOMER DRAWING			
	DRFT:	REV	DO		
	 THIRD ANGLE PROJECTION	DRAWING NO.:	SHEET	1/1	
	MM (INCH)	DO NOT SCALE DRAWING	SCALE	1:1	